

THE EFFICIENT RECOVERY OF KAOLIN FROM A HYDROCYCLONE PLANT MIDDINGS STREAM UTILISING IMHOFLOT G-CELL PNEUMATIC FLOTATION

Michael Battersby, Maelgwyn Mineral Services, Cardiff, UK

Rainer Imhof, Maelgwyn Mineral Services, Dorsten, Germany

Michael Fletcher, Maelgwyn Mineral Services, Cardiff, UK

Franz Puder, Gebr. Dorfner GmbH & Co, Hirschau, Germany

Abstract

The traditional processing of kaolin is achieved by dispersion of the mined ore and classification by multistage hydrocyclone plants. Inefficiencies inherent to cyclones produce a middlings product that is commonly disposed of back into the quarry. The Imhoflot G-Cell is an innovative pneumatic flotation process that can be used to recover this previously wasted middlings stream. The technology uses centrifugal forces to assist in the separation of the froth phase from the tailings and consequentially reduce the residence time in the separating vessel. This paper describes the testing, design and installation of a pneumatic flotation plant for kaolin recovery at the Dorfner kaolin plant in Germany.

Introduction

Kaolin's (china clay) major constituent is the mineral kaolinite, which is a hydrated aluminium silicate, $\text{Al}_2\text{Si}_2\text{O}_5(\text{OH})_4$. Kaolin is formed by the decomposition of the mineral feldspar by water and heat and can commonly be found in two types of deposits, primary and secondary. Primary deposits, which are most commonly found in Europe, consist of the clay occurring in situ in the kaolinised rock. Secondary deposits, found in the Americas, are created when water has transported the clay from primary deposits and laid it down in new beds. This natural washing process leaves secondary deposits comparatively pure.

Kaolin particles are predominantly below $25\mu\text{m}$ and are flat shaped particles. This means that industrial separation is commonly achieved by the dispersion of the mined ore and classification using multistage hydrocyclones. The kaolin reports to the overflow which is then reprocessed in other smaller cyclones. Due to inefficiencies associated with hydrocycloning, most plants are not able to produce clean quartz, feldspar and kaolinite products and after the 4th or 5th hydrocyclone stage, the underflow cannot be separated further, resulting in the production of a middlings stream that is either sold cheaply to the cement industry or used as back fill in the quarry. This middlings stream can be treated via flotation, but due to the environmental impact of using cationic collectors (amines) the flotation plant has to be operated in a closed water circuit.

The Dorfner mine is situated just outside the city of Hirschau (Oberpfalz) in south-eastern Germany, 70km east of Nuremberg. The Dorfner Company has been operating for over 100 years processing and refining minerals such as quartz, feldspar and kaolin from the Hirschau-Schnaittenbach (HS) deposit. Kaolins from the HS deposit are characterised by high concentrations of the rare elements Barium (Ba), Strontium (Sr), Lead (Pb), Copper (Cu) and Phosphorous (P). The occurrence of these trace elements with the kaolin originates from the decomposed potassium feldspar of the kaolinised arcoses. The usage of flotation as a beneficiation route at Dorfner also helps to enhance the rejection of these rare elements, in particular the high lead contamination.

The mine uses a sophisticated hydrocyclone plant and has an extensive knowledge of pneumatic flotation due to their exclusive use of the Bahr-Cell on kaolin flotation. The previous float plant was limited in its throughput as well as requiring a cleaning stage to produce a final grade product. The use of amine reagents in combination with ultra-fine kaolin results in a very stable froth that causes significant handling and pumping problems in the cleaner stages. With the Dorfner mine looking to expand its production the current flotation plant could not successfully handle the additional flowrate and Maelgwyn Mineral Services (MMS) were approached to perform tests and trials for upgrading the flotation plant. With the planned expansion, the middlings product would make up 5-6t/hr, with an effective flotation plant it would have the ability to produce an additional 4t/hr of high value kaolin.

The quality of kaolin is most commonly measured by the mass percentage loss on ignition (LOI) at 1050°C. The theoretical maximum LOI of pure kaolin is reported as 13.9%.

Development of the Imhoflot G-Cell

The term pneumatic flotation is generally associated with flotation where the aeration of the pulp is conducted outside of the flotation cell. This is the main differentiating factor between pneumatic flotation and conventional tank flotation. The energy required by conventional cells to keep particles in suspension and generate bubbles is now focused solely at the production of very fine bubbles in the Imhoflot system and the suspension of particles is catered for in the surplus energy of the system. The external aeration is usually achieved either by utilising a simple venturi system in a pipe with downcomers or by using specialised fine bubble generation technology. This fine bubble generation technology is designed by Dr. Rainer Imhof and utilised in the Imhoflot system.

The design objectives for Imhoflot pneumatic flotation is to separate and optimise the independent process steps that make up froth flotation i.e. aeration, bubble-particle contact and froth separation. The aerator is self-aspirating and uses a high shear ceramic multi-jet venturi system operating at around 2.5 bar (250 kPa) back pressure. Bubble sizes generated start with ultra fine bubbles at around 10µm but also bubbles in the 2mm to 3mm size range can be found due to the subsequent coalescence of bubbles that takes place. The high shear aerator reactor is designed to maximise the attachment of bubbles to all hydrophobic particles. Therefore the aerator can be seen to tend to the generation of bubbles as well as the bubble-particle contact required for successful

flotation. In the original design of the Imhoflot cell, the V-Cell, the aerated pulp was introduced upwards into the cell by means of a ring distributor system and nozzles. Residence time in the cell was generally in the order of three to four minutes. MMS over the last few years have developed the concept of using centrifugal forces to speed up the separation of concentrate and enhance the removal of the froth phase. This is achieved by introducing the aerated feed tangentially into the separating vessel thus creating specific rotational speeds in the cell. The cell is not designed as a gravity separator and the rotational speeds are not high enough to strip coarse particles from the froth. However the centrifugal froth separation has now reduced the residence time in the cell to around 30 seconds which results in a multi-fold increase in flotation unit capacity.

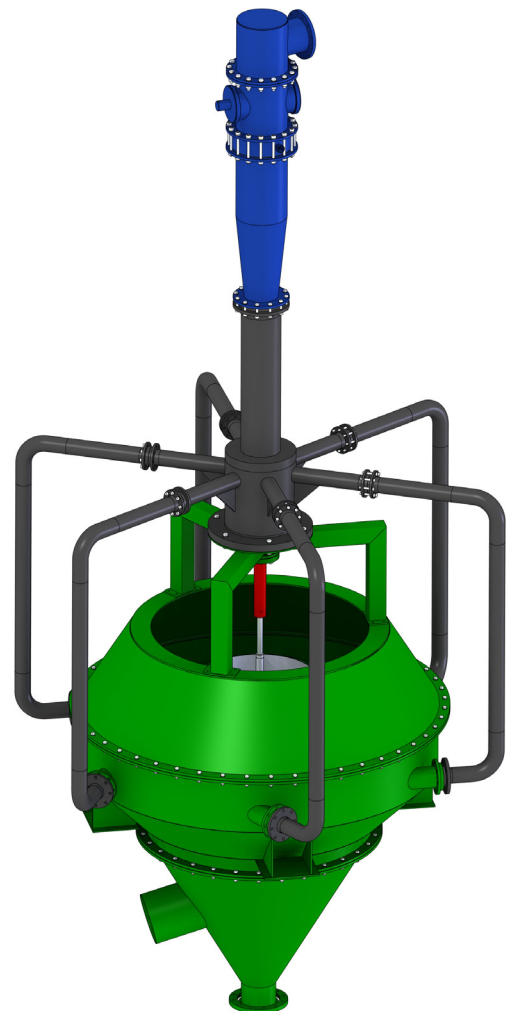

Figure 1: 3D Model of an Imhoflot G-Cell G-28

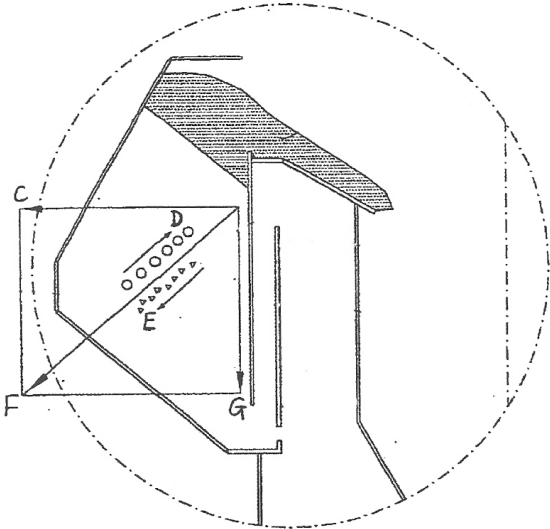

Figure 2: Schematic detailing the forces working on particles in the G-Cell

Figure 2 above details the forces acting on the particles in the slurry inside the G-Cell. The downward force (G) is the force exerted by gravity and can be calculated using Newton's second law of physics, which states:

$$F_G = m \cdot a$$

$F_G = \text{Gravitational Force}$

$m = \text{mass}$

$a = \text{Gravitational Acceleration}$

The acceleration of an object due to gravity is constant and equal to 9.8m/s^2 . For the purpose of this example, we can ignore the mass of the object because it will be variable for different size particles entering the separating vessel. We can therefore say that all particles entering the separating device will be exerted to a gravitational acceleration (F_g) of 9.8m/s^2 and in a downward direction. By using the cylindrical shape of the vessel, and injecting the slurry tangentially into it, it is possible to create a centrifugal force on the aerated pulp in the separating vessel. The following equation is a derivative of Newton's second law and can be used to determine the centrifugal force experienced by a particle in the rotating pulp:

$$F_C = m \cdot v^2 / r$$

$F_C = \text{Centrifugal Force}$

$v = \text{rotational velocity}$

$r = \text{radius}$

Therefore at a predetermined speed and radius (and ignoring the mass of the object, as before) it can be calculated that the centrifugal acceleration experienced by the object would be 9.8m/s^2 . This force will be exerted in an outward direction and the resultant force diagram is shown below:

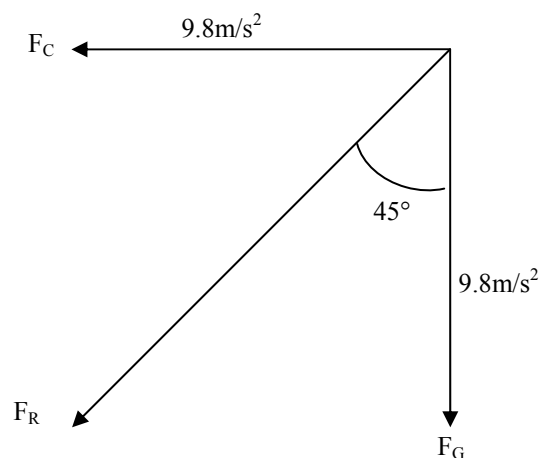

Figure 3: Example of a possible resultant force diagram that a particle is subject to in an Imhoflot G-Cell

F_R is the resultant force that is experienced by a particle in the pulp. To calculate the resultant force, we use the Pythagoras theorem. For example, when the centrifugal acceleration is 9.8m/s^2 , the resultant force experienced by the slurry will be 13.86m/s^2 at an angle of 45° . The resultant force on the particle in the slurry is larger than that of the gravitational force alone experienced in other flotation systems. This increased force in the system encourages hydrophilic particles to drop out of the system faster and thus allowing a much shorter residence time in the separating vessel. The additional force added to the particles aids in the reduction of the entrainment of hydrophilic particles into the froth. This results in a product being produced at a higher selectivity and hence producing better grades in the froth. The resultant force on the pulp creates an angled pulp / froth interface. This is beneficial as it allows the froth to essentially "flow" over the interface towards the inner channel thus aiding in the removal of froth from the system. This faster froth removal ensures that valuable particles are removed from the system before they can

detach from bubbles and drop back into the pulp to be lost to the tails. This, in combination with the generation of fine bubbles in the high shear aerator results in better recoveries of valuable minerals in the finer size fractions. This increased performance in the flotation system enables the separating device to be smaller in size and more cost effective than standard flotation cells.

Laboratory Trials

Because of Dorfners extensive experience with kaolin flotation, limited laboratory flotation trials were conducted in order to determine the correct reagent suite and operating parameters for the new flotation plant expansion. The feed material that was tested had a head grade of 10.6% LOI (approx. 75% kaolinite) and was 100% minus 40µm. The overall required concentrate grade was an LOI of 13.4% (96% kaolinite). All tests were conducted in a 3 litre Denver type laboratory flotation cell and a rougher cleaner circuit was tested as shown in Figure 4.

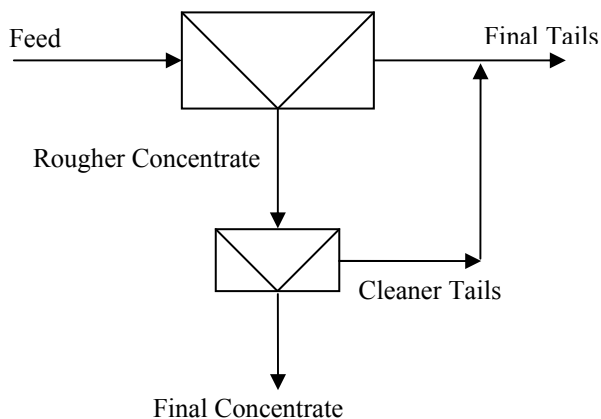

Figure 4: Laboratory flotation test procedure followed

The feed material was conditioned with reagents at a high pulp density of 500g/l. H₂SO₄ was used for pH control and adjustment and the Amine 3305-1 from Clariant was used as the collector and frother. The collector dosage was kept relatively constant and was measured as between 400 and 600g/t. The rougher concentrate was collected for a residence time of approximately 4 minutes, transferred to another flotation cell, additional water added and re-floated for an additional 3 minutes. During conditioning the impeller speed was set at 900rpm and increased to the generic 1300rpm during flotation.

Effect of pH

The standard pH of tests conducted was set at 2.5 and was established from prior flotation knowledge. Two additional tests were conducted at higher pH's in order to determine the effect it made on the flotation performance.

Table 1: Effect of pH on flotation performance

pH	Yield (%)	Recovery (%)	Conc. Grade (% LOI)
2.5	71.7	90.0	13.3
5	73.6	89.8	12.9
7	78.6	91.0	12.8

Table 1 shows that there is a distinctive trend associated with the pH of the flotation pulp. As the pulp pH is increased, the selectivity of the float decreases resulting in a higher yield and decrease in concentrate grade. Although higher yields can be favourable, the final product grade of the concentrate at higher pH values was well below the selection criteria of an LOI of 13.4%.

Effect of conditioning time

Conditioning the feed at a high pulp density enables the mechanical energy transferred to the particles to be increased. In addition to conditioning the material at a high pulp density, the amount of time allowed for particle / reagent contact is essential to successful flotation. As show in Table 2, with a conditioning time of 1 minute, the desired grade is not achieved in the final concentrate and yield increases due to the lower selectivity of the float.

Table 2: Effect of pH on flotation performance

Cond. Time (min)	Yield (%)	Recovery (%)	Grade (% LOI)
1	75.5	88.7	12.7
3	68.5	84.9	13.4

Effect of flotation pulp density

After high density conditioning, the flotation pulp is watered down significantly to a floatable density. Previous experience dictated that a value of approximately 100g/l would ensure that the required grade was achieved. Table 3 below shows the effect seen when the flotation density is either too thick or too thin. Both extremes result in lower grades in the final concentrate due to loss of selectivity of the float.

Table 3: Effect of flotation pulp density on flotation performance

Density (g/l)	Yield (%)	Recovery (%)	Grade (% LOI)
44	75.9	90.2	12.7
105	71.7	90.0	13.3
207	80.4	92.9	12.4

Effect of water quality

The majority of laboratory tests were completed using tap water during flotation. Due to the nature of anime flotation, the plant's water needs to be recycled and tests were conducted to confirm that there was no performance loss due to recycled water.

Table 4: Effect of water quality on flotation performance

Water Source	Yield (%)	Recovery (%)	Conc Grade (LOI)
Tap	71.7	90.0	13.3
Plant	68.5	84.9	13.4

It can be seen that the final grade produced is not negatively affected by the water, however there is a slight reduction in yield.

The results from the laboratory flotation can be summarised as follows:

- Maximum kaolin grade achievable was 13.5% LOI from a feed grade of approximately 10.6% LOI.
- Kaolin recoveries of 85% to 90%.
- Kaolin yields of 65% to 75% are achievable but dependant on the feed quality.
- Laboratory tests show that the use of conventional flotation technology would require a cleaner circuit to produce the required grade.
- Low pulp densities, increased conditioning times and low pH environments would be required for the flotation performance to be satisfactory.

Industrial Trials

Following the results obtained in the laboratory, an industrial size G-Cell (1.7m in diameter) was used to test the full middlings stream. The low solids concentration (below 100g/l) required to produce a final grade product was treatable in this size of G-Cell without difficulty. Although pneumatic flotation has shown in the past that it produces a higher grade product, the target set by Dorfner was very stringent and so a froth washing system was installed by MMS. Due to the rotational movement of the froth in the G-Cell, a single spray bar can be used to get coverage of the entire forth area as well as ensure deep forth penetration without destroying the produced froth. The use of a froth washing system also resulted in a thinner froth being produced which would be beneficial for pumping of the froth to downstream processes.

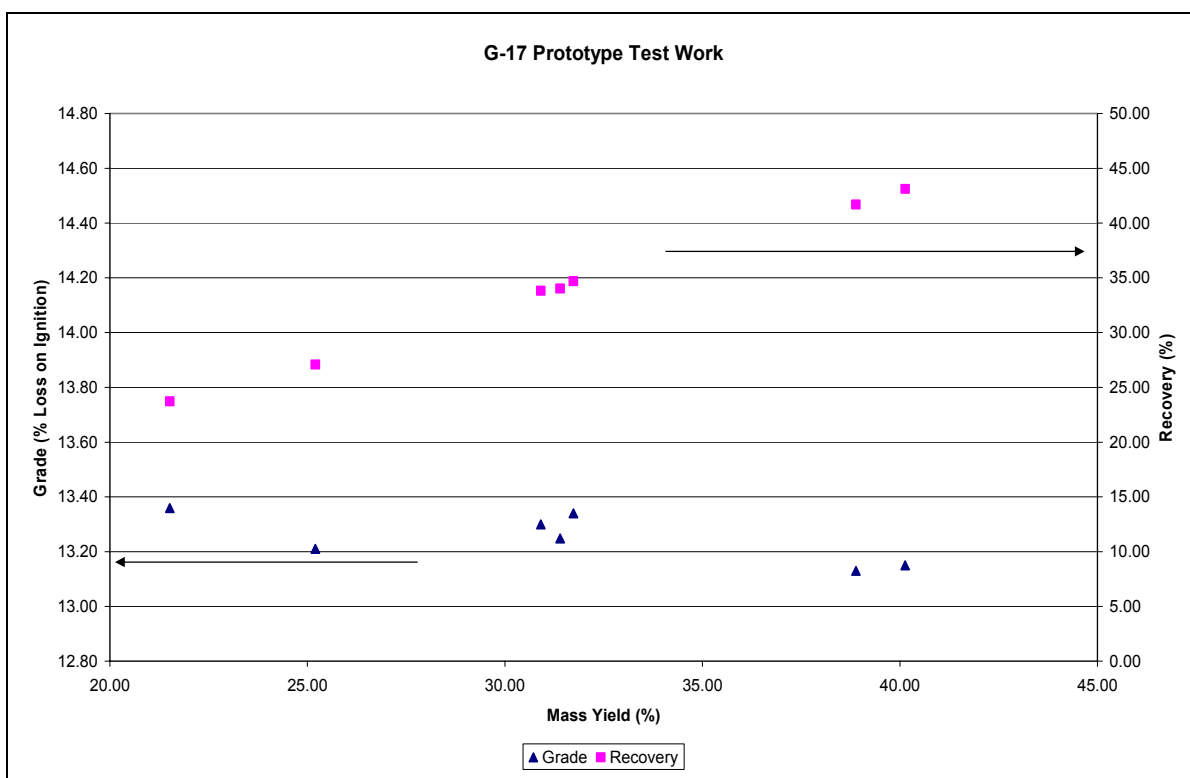

Figure 5: Selected results obtained during pilot plant trials

Figure 5 shows some of the results obtained during the pilot plant trials with the single G-17 G-Cell. The feed to the cell varied from between 70 to 80m³/hr and the density was kept below 100g/l. The most promising results were obtained at densities as low as 50g/l. This is unexpected as the lab results dictated that such a low density would result in a loss of selectivity. It is believed that the advanced aeration system on the G-Cell results in very good bubble particle contact even at the very low densities. A single pass through the one G-Cell was able to obtain the following results; 35% recovery of kaolinite at 13.3% LOI with a yield of 31.5%.

With the success of the laboratory flotation and the pilot plant proving that the IMHOFLOT G-Cell was able to achieve the final grade without the need for cleaning, the approval was given to invest in an IMHOFLOT flotation plant. To ensure that an economical recovery of above 85% was achieved, the plant would require 3 G-18 G-Cells (1.8m in diameter) operating in series. This size of plant could be comfortably retrofitted into the old flotation plant building and the available space. Figure 6 gives a process flow diagram of the 3 stage flotation plant. Water is recycled in the plant from the final tailings by the use of a cyclone pack and vacuum drum filter, as well as

from the concentrate via the thickener overflow. The process water tank is then topped up with fresh water as is required using a float valve. The conditioning time in the cascade is approximately 4 minutes as dictated by the laboratory trials. The cascade is designed with three compartments, of which the first two are open at the bottom and allows the pulp to be conditioned with flotation reagents at a high density. The third compartment is feed from the second via an overflow and process water is added to dilute the pulp before flotation.

The concentrate produced is treated with a defrothing agent to aid the pumping and settling in the lamella style thickener where the thickened concentrate is neutralised using NaOH and pumped to a storage silo for further treatment and sale. The filter cake produced from the tailings is removed via conveyor belt and stock piled.

The plant provided by MMS to Dorfner was a full turnkey installation. Included in the battery limits for the delivery was the electrical system, flotation cells, pumps, automation, control protocol and integration with the existing equipment into the control system.

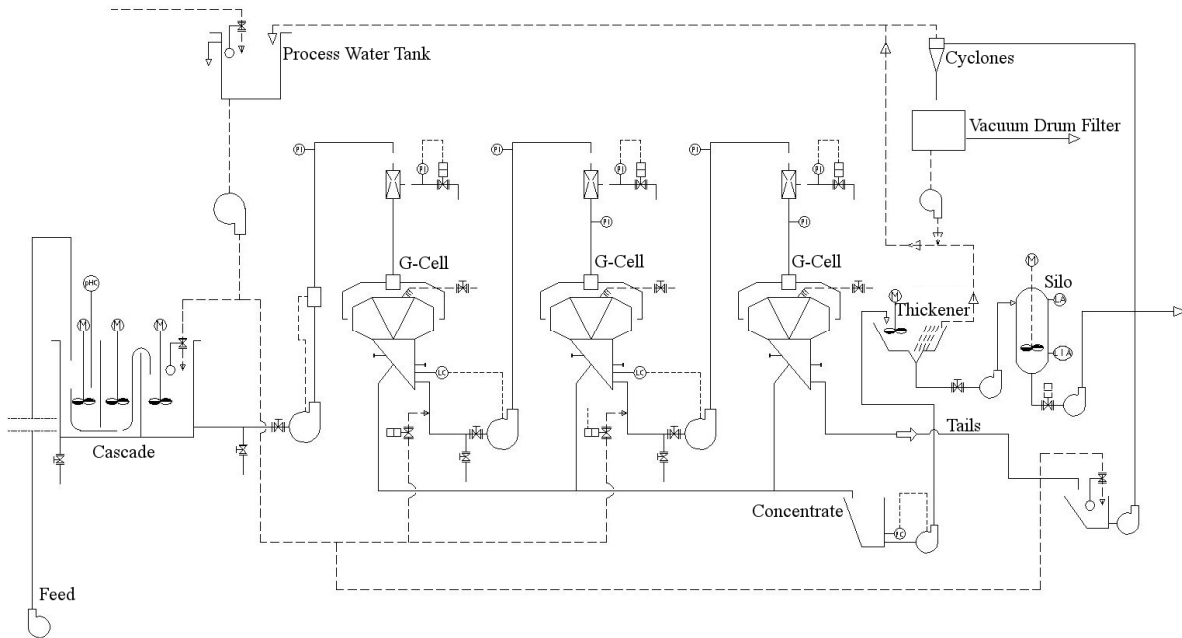

Figure 6: Dorfner kaolin flotation plant

Commissioning and Installation

The plant was commissioned successfully in June 2005 and achieved the desired results from the very first commissioning run. The full flotation plant is shown in Figure 7.



Figure 7: Dorfner flotation plant installed

During the commissioning of the plant, a sample from each of the three G-Cells was taken to confirm the performance down the line of flotation cells. The results obtained are presented in Table 5.

Table 5: Individual G-Cell Grades obtained during commissioning

	Feed	G-Cell 1	G-Cell 2	G-Cell 3	Tails
LOI	8.18	12.71	12.93	12.01	2.37

When these samples were taken, the feed grade to the flotation plant was significantly lower than is normally expected and resulted in low concentrate grades being produced. However, the results showed that each of the 3 G-Cells was able to produce a high grade product with good air flow rate control on the third cell.



Figure 8: Froth washing installed on G-Cells

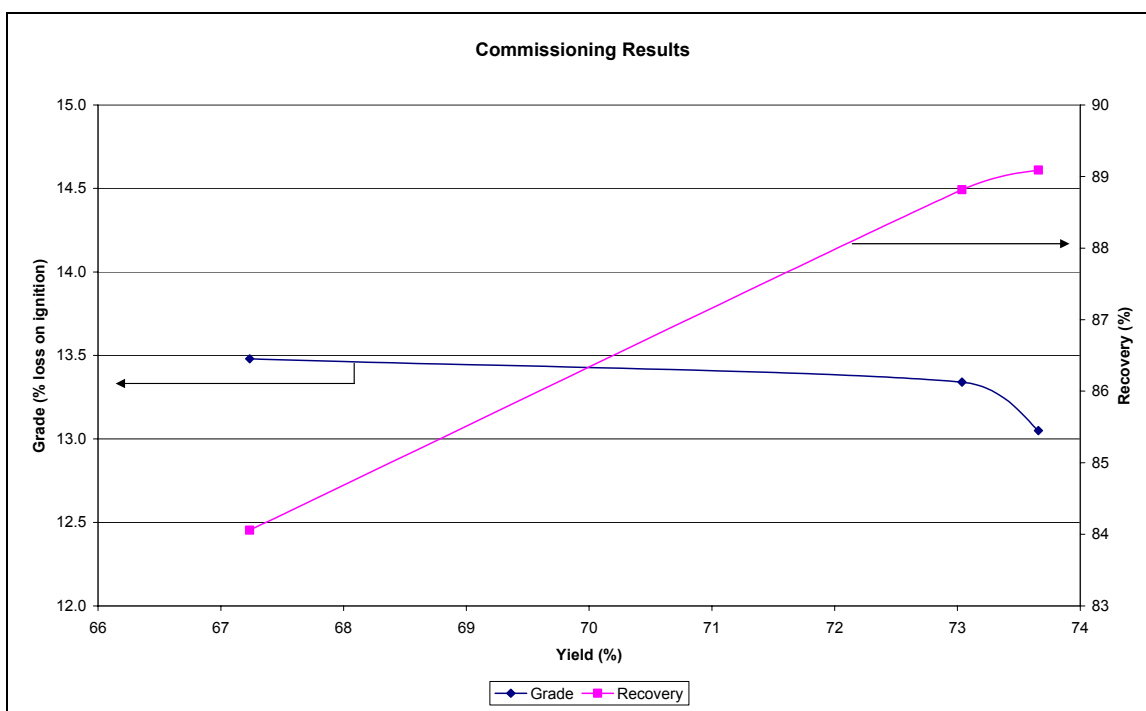

Figure 9: Results obtained during the commissioning of the G-Cell plant

The overall performance of the plant is shown in Figure 9. As the yield of the plant was increased, the recovery increased as expected, but the loss of grade at the higher end was lower than expected. The yield increased from approximately 67.2% up to 73.6% with a corresponding grade decrease from an LOI of 13.5% to 13.1%.

Table 6: Detailed analysis of feed, concentrate and tails

Element	Mass %		
	Feed	Conc	Tails
SiO ₂	53.80	48.50	72.90
Al ₂ O ₃	32.50	37.10	16.50
Fe ₂ O ₃	0.18	0.20	0.12
TiO ₂	0.74	0.19	2.16
K ₂ O	1.35	0.46	3.52
Na ₂ O	0.10	0.04	0.13
PbO	< 0,008	0.01	< 0,008
BaO	0.01	0.03	0.01
% LOI @1000°C	10.97	13.34	4.55

Conclusions

The Imhoflot G-Cell plant was delivered, installed and commissioned within three months of the order being

received from Dorfner. It was successfully commissioned without any major commissioning problems and was fully operational in July 2005. With the use of froth washing the three stage plant produced an acceptable concentrate without the need for further cleaning resulting in considerable cost savings. The residence time of the complete G-Cell installation is less than 120 seconds. This can be compared for this application of eight minutes of conventional roughing time and a further six minutes in a required cleaner section.

Dr Imhof supplied his first pneumatic flotation plant in 1987. Since then he has designed and supplied over 110 cells treating a whole range of materials including copper sulphide and oxide ores, gold, coal, iron ore, slags, soil remediation and a range of industrial minerals. The development of centrifugal froth removal providing high performance separation with significantly reduced residence time now offers further reductions in installation costs of flotation plants. The first two successful installations detailed here demonstrate the reliability of a flotation plant based on the G-Cell development.

Bibliography

Battersby, M.J.G., Imhof, R.M., Brown, J.V., (2003). *The Imhoflot G-Cell – An Advanced Pneumatic Flotation*

Technology for the Recovery of Coal Slurry from Impoundments. SME 2003 Annual Meeting 24-26 February 2003, Cincinnati, USA.

Battersby, M., Fletcher, M., Imhof, R., Singh, A, Puder, F., (2005). *The Advantages of the Imhoflot G-Cell Pneumatic Flotation Process with Centrifugal Froth Removal – Two Case Studies*. Randol Innovative Metallurgy Forum, 21-24 August 2005, Perth Australia

Bahr, A., Imhof, R.M., Ludke, H. (1985) *Application and sizing of a pneumatic flotation cell*. Min. Proc. Congress, Cannes, France

Hill, R.D., (2000) *The White Stuff: Fillers and Coating Pigments for the Paper Industry*. Presented at Asia Pulp & Paper, 5 - 6 December 2000, Grand Hyatt, New Delhi, India

Imhof, R.M., Lotzien, R., Sobek, S. (1993). *Pneumatic flotation: a reliable procedure for a correct plant layout*. XVIII International Mineral Processing Congress Sydney, Australia 23-28 May 1993 pp 971-978.

Imhof, R.M., Sanchez, S.P., Fuentes, G.B., Latorre, G.J., Conejeros, V.T., Carcamo, H.G., (1997). *Aplicacion de la flotacion neumatica en Chile*. Minería Chilena. Vol 16 No. 189, pp97-103

Imhof, R.M., Brown, J.V., (2000). *Imhoflot – Evolution of pneumatic flotation*. Major Trends in Development of Sulfide Ores Up-Grading in the 21st Century Conference Proceedings , 24-28 April 2000, Norilsk, Russia

Imhof, R.M., Battersby, M.J.G., Ciernioch, G. (2002). *Pneumatic flotation – An innovative application in the processing of potash salts*. SME 2002 Annual Meeting, 25-27 February 2002, Phoenix, AZ, USA Preprint 02-162

Imhof, R.M., Battersby, M.J.G., Brown, J.V., Lotzien, R.M., Kleefeld, J., (2003). *Development of Pneumatic Flotation Incorporating Centrifugal Separation*. XXII International Mineral Processing Congress, 28 October-3 September 2003, Cape Town, South Africa

Imhof, R.M., Battersby, M.J.G., Parra, F., Sanchez-Pino, S., (2005). *The Successful Application of Pneumatic Flotation Technology for the Removal of Silica by Reverse Flotation at the Iron Ore Pellet Plant of Compania Minera Huasco, Chile*. Centenary of Flotation Symposium, 5 – 9 June 2005, Brisbane, Australia

Mohanty, M.K., Huang, Z., Gupta, V., Biswal, S.K., (2005). *Performance of the Imhoflot G-Cell for Fine Coal*

Cleaning. Centenary of Flotation Symposium, 5 – 9 June 2005, Brisbane, Australia

Sanchez-Pino, S., Imhof, R.M., Sanchez-Baquedano, S., Rojas-Tapia, F., Fernandez-Garcia, M., (2003) *Pneumatic Flotation Technology – An Interesting Experience in the Chilean Mining Industry*. CIM 35th Canadian Mineral Processors Operators Conference, 21-23, January 2003. Ottawa, Canada